

# Hygienic lock URK

## URK

These complete hygiene appliances are placed in a hygienic lock at the entrance of the production unit. The system provides an easy and effective cleaning of footwear using horizontal brushes, a hand disinfection unit and a controlled access unit.

By inserting both hands in one move, 2 sensors activate the disinfection of the hands. When finished this process the exit blockade will be unbolted and one person at the time can pass the turnstile. When leaving the station the footwear is cleaned and disinfected by the rotating brushes. When leaving the production area in the other direction, the turnstile unit is always open and a sensor activates the rotating brushes, which remove all the dirt and disinfect the footwear at the same time.

The basic URK machine can be upgraded with vertical brushes for cleaning of boot sides such as DRV/300

- modern and ergonomic design in stainless steel
- equipped with recent technologies
- available in left or right version



1

- brushes are easy to be replaced
- long durability of the brushes
- 4 years warranty on the brushes



2

- highlighted hand openings
- the edges are equipped with rubber bands for hand protection
- the system is activated by sensors



3

- the brushes are activated by 2 sensors
- simple operation



4



- rounded edges and corners for safety
- robust design
- quality and reliability
- little maintenance



# Hygienic lock URK

There are left and right operating stations, depending your entrance area. When choosing the left operating system one should know the hand disinfection unit is on the left also (see figure). Please keep this in mind when ordering product.

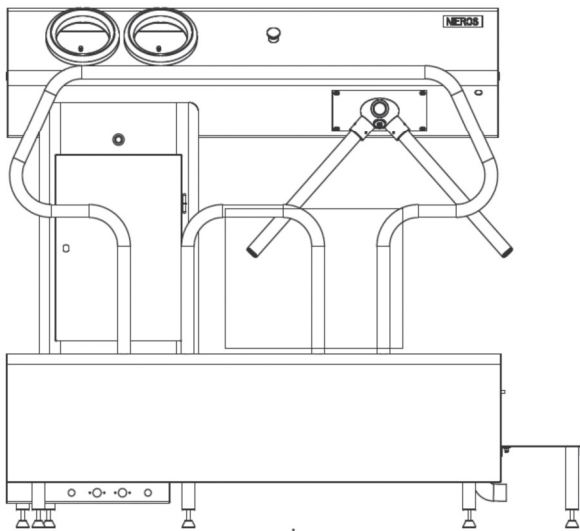

left operating option

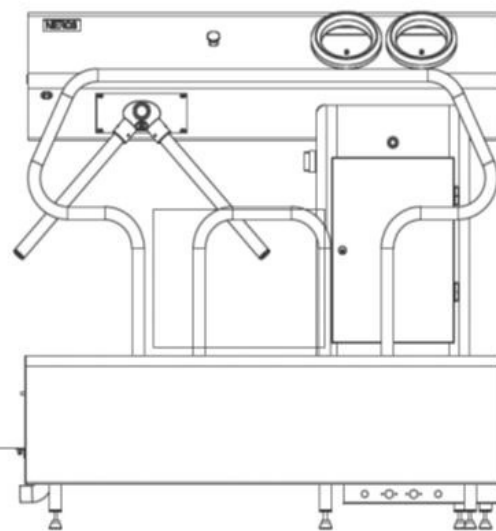

right operating option

<b>Order number</b>	181210238 ( <i>left operating station</i> ) 181210272 ( <i>right operating station</i> )
<b>type</b>	Urk
<b>consumed power</b>	0,7 kW
<b>power supply</b>	3 x 400 V - 50 Hz
<b>number of brushes</b>	2
<b>dimension brushes</b>	Ø190 – 1020 mm
<b>weight</b>	260 kg
<b>protection type</b>	IP 65
<b>water inlet / outlet</b>	¾" / DN50
<b>dimensions system (l x w x h)</b>	1810 x 975 x 1630 mm

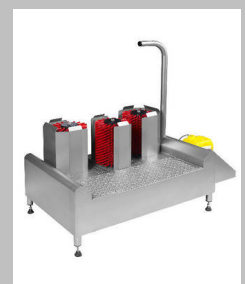

Optional upgrade:  
DRV/300 boot cleaner (18210115)

